

SUBJECT: STABILIZER TRIM STOP/SCREW MODIFICATION

MODEL/S/N AFFECTED: M20J - S/N 24-0001 THRU 24-1694 & 24-3000 THRU 24-3172  
M20K - S/N 25-0001 THRU 25-1230  
M20L - S/N 26-0001 THRU 26-0041  
M20M - S/N 27-0001 THRU 27-0058

TIME OF COMPLIANCE: AT OWNERS DISCRETION

INTRODUCTION:

There have been occasions when the elevator trim control wheel has been manually turned to the extreme nose up or nose down condition and the electric trim system was unable to move the trim indicator nut off the stop at the next electrically activated command. Manual movement must be the initial action to get the trim indicator nut off the stop, then the electrical system will operate normally.

If an aircraft owner has experienced this situation in his routine habits of operation, the incorporation of this Service Instruction may be desired.

INSTRUCTIONS:

**M20J, M20K, M20L, M20M AIRCRAFT MODELS**

1. Remove belly access panels or smooth belly fairing to gain access to lower side of the trim control wheel assembly.
2. Remove trim indicator wire from trim screw nut by loosening set screw(s) that restrain trim wire.
3. Remove any brackets connected to gear box bolts (Index 1, Figure SI M20-88-2) both sides if required. Different models have different type of brackets.

**NOTE:**

**You do not have to open the gear box housing to accomplish this SI.**

4. Remove cotter pin, washer and pin that secures trim tube universal joint to trim screw (Figure SI M20-88-1).
5. Loosen gear box bolts (Index 1, Figure SI M20-88-2) if not already done, and both NAS428-3-4 bolts (Index 2, Figure SI M20-88-2) to give slack in roller chain between upper and lower sprocket of trim control wheel assembly.
6. Remove #25 master link of roller chain and remove chain. This may be done from inside aircraft cabin if desired, after removing chain and sprocket cover.
7. Remove roll pin, P/N RPA52-028-125-1125 holding lower sprocket, P/N 740049, to gear box shaft. Remove sprocket.
8. Loosen set screw, #6-32 x 1/8, in each existing trim stop so they will unscrew easily. Remove aft trim stop (DN stop) from trim screw (Fig. SI M20-88-1).
9. Gear box assembly should move freely. Tilt gear box (forward end downward) until trim screw indicator nut will clear slotted bracket that guides/restrains trim screw indicator nut during its forward and aft travel.
10. Turn sprocket shaft to remove trim screw indicator nut. When trim screw indicator nut is clear of bracket gear box assembly can be removed from aircraft and put on work bench to complete modification.
11. Remove forward stop nut (UP stop) from trim screw.

**If aircraft model being modified is M20K, M20L or M20M, procede to Step 22 and complete subsequent steps.**

**If M20J model is being modified continue with Step 12 and complete all remaining steps.**

12. Measure and document lateral free play in trim screw shaft (length wise play) as assembled in the gear box assembly.
13. Remove forward snap ring from trim screw. Reference Figure SI M20-88-1
14. Lightly tap trim screw at forward end, with a plastic mallet, to drive trim screw, bushings, washers, gear and aft bearing from gear box assembly housing. Bearings are installed with locktite (Blue) at assembly, so some effort may be required to break it loose. **DO NOT DAMAGE BEARING NOR HEAT THE HOUSING.**
15. When existing trim screw, and components attached to it, comes free from gear box housing, the bushings, washers, gears, woodruff key, snap ring and aft bearing will be removed. Retain components, except woodruff key, to place back on new trim screw (Fig. SI M20-88-1).

**NOTE**

**Refer to the Illustrated Parts Catalog Figure "Stabilizer Trim Control System, Forward", for the model being modified if needed for additional view of assembly.**

16. Install existing snap ring, P/N NAS51-37 on mid groove of new trim screw, P/N 740016-019. Reassemble shim(s), bearing, bushing, washer(s), Boston gear, new woodruff key, washer(s) and spacer on new trim screw.
17. Inspect for adequate and proper lubrication of gear box and trim screw assembly. Refer to appropriate Service and Maintenance Manual, Section 5, Lubrication Guide for proper lubricant of the trim gear box assembly.
18. Insert new assembly into gear box assembly. Use Loctite (Blue) on aft bearing flange.
19. Install other snap ring in end groove of new trim screw as it protrudes through forward bearing.
20. Measure lateral free play of assembled trim screw to ensure that free play does not exceed 0.010 TIR.
21. Add NAS70CL390-625, shim washer(s) under AN960-616L washer or under either snap ring as needed to maintain 0.010 TIR free play. Trim screw assembly will require removal from gear box housing again if shims are required under AN960-616L washer(s).

**CAUTION**

**The new modified trim screw/gear box assembly should be shimmed for a maximum lateral free play of 0.010 TIR.**

**The steps below should be used on all aircraft models for retrofit of the stepped stop nuts configuration on trim screw. Pick up M20K, M20L & M20M retrofit steps here from Step 11.**

22. Install one jam nut (UP stop side), P/N 740086-003 (M20J) or 740086-001 (M20K, M20L or M20M), on trim screw. Screw toward gear box housing leaving approximately 0.375 inch gap on threads between gear box and jam nut (Figure SI M20-88-2).
23. Install one stepped stop nut (UP stop), P/N 740086-007 (M20J) or 740086-005 (M20K, M20L or M20M) on trim screw. Screw toward gear box housing and against jam nut installed in step 22.

**CAUTION**

**The stepped portion of stop nut must be facing away from gear box housing.**

24. Position gear box/trim screw assembly to lower trim wheel assembly so new trim indicator nut, P/N 740086-011 (M20J) or 740086-009 (M20K, M20L or M20M) can be placed on trim screw and screwed in place to proper position within slotted bracket area. This is the reverse of Steps 9 & 10.
25. Install other stepped stop nut (DN stop) (stepped side toward trim indicator nut) on trim screw.
26. Install other jam nut on trim screw against stop nut (DN stop).
27. Reverse Steps 2 thru 7 to reposition gear box assembly back on trim wheel assembly. Do not tighten trim indicator wire set screw at this time. Position all other brackets but do not tighten bolts holding gear box assembly to trim wheel assembly (Fig. SI M20-88-2).
28. See Section 27-40-01, para. 5, for instructions on adjustment of trim wheel chain tension. Tighten gear box bolts with attached brackets in proper position.
29. Reference appropriate Service and Maintenance Manual for the model aircraft being modified for Stabilizer Trim Control Rigging, Section 27-40-01, para. 1 & 2. This instruction pertains to the original configuration stop nut rigging procedure but is appropriate for the new stepped stop nut configuration with the addition of instructions for the jam nuts and stop nuts to be torqued together prior to the set screw in each jam nut being tightened.

**CAUTION**

**Each jam nut and stepped stop nut MUST be torqued together with wrenches, then the set screw in each jam nut tightened down on trim screw. Before proceeding further, run trim system through at least two complete nose up and nose down cycles to ensure stops are correct and did not move during the tightening of set screws or torquing procedures. Refer to Section 27-40-01 for proper negative and positive angles for stabilizer in full nose up and full nose down positions.**

30. After proper stabilizer trim control rigging is completed, refer to Section 27-40-01, para. 3, for stabilizer trim indicator rigging.
31. When all trim system components are verified to be secure and rigging is complete and proper, install belly skin(s).
32. Enter compliance note into aircraft logbook and return aircraft to service.

**WARRANTY:** Mooney Aircraft Corporation is submitting this SI as notification of availability of retrofit kit to the field. There will be no warranty consideration for the purchase of kit components or for installation of kit for this SI.

REFERENCE

DATA: The appropriate Mooney Service and Maintenance Manual, SECTION 27-40-00 and Illustrated Parts Catalog figure for the model aircraft being modified.

PARTS LIST: KIT P/N: **SI M20-88-1 (M20J ONLY)**

ITEM	P/N	DESCRIPTION	QTY
1.	740016-019.	TRIM SCREW.	1
2.	740086-003.	JAM NUT.	2
3.	740086-007.	STOP NUT	2
4.	740086-011.	TRIM INDICATOR NUT	1
5.	#8-32 x 1/4.	SET SCREW, TRIM INDICATOR NUT/WIRE	1
6.	AN565D4H2	SET SCREW, JAM NUT	2
7.	NAS70CL390-625	WASHER, SHIM	2
8.	AN960-616L	WASHER.	2
9.	AN380-2-2	PIN, COTTER.	1
10.	#204	KEY, WOODRUFF.	1

KIT P/N: **SI M20-88-2 (M20K, M20L, M20M ONLY)**

1.	740086-001.	JAM NUT.	2
2.	740086-005.	STOP NUT	2
3.	740086-009.	TRIM INDICATOR NUT	1
4.	#8-32 X 1/4.	SET SCREW, TRIM INDICATOR NUT/WIRE	1
5.	AN565D4H2	SET SCREW, JAM NUT	2
6.	NAS70CL390-625	WASHER, SHIM	2
7.	AN960-616L	WASHER.	2
8.	AN380-2-2	PIN, COTTER.	1
9.	#204	KEY, WOODRUFF.	1

FIGURES/  
TABLES: See Figures below and on next page.

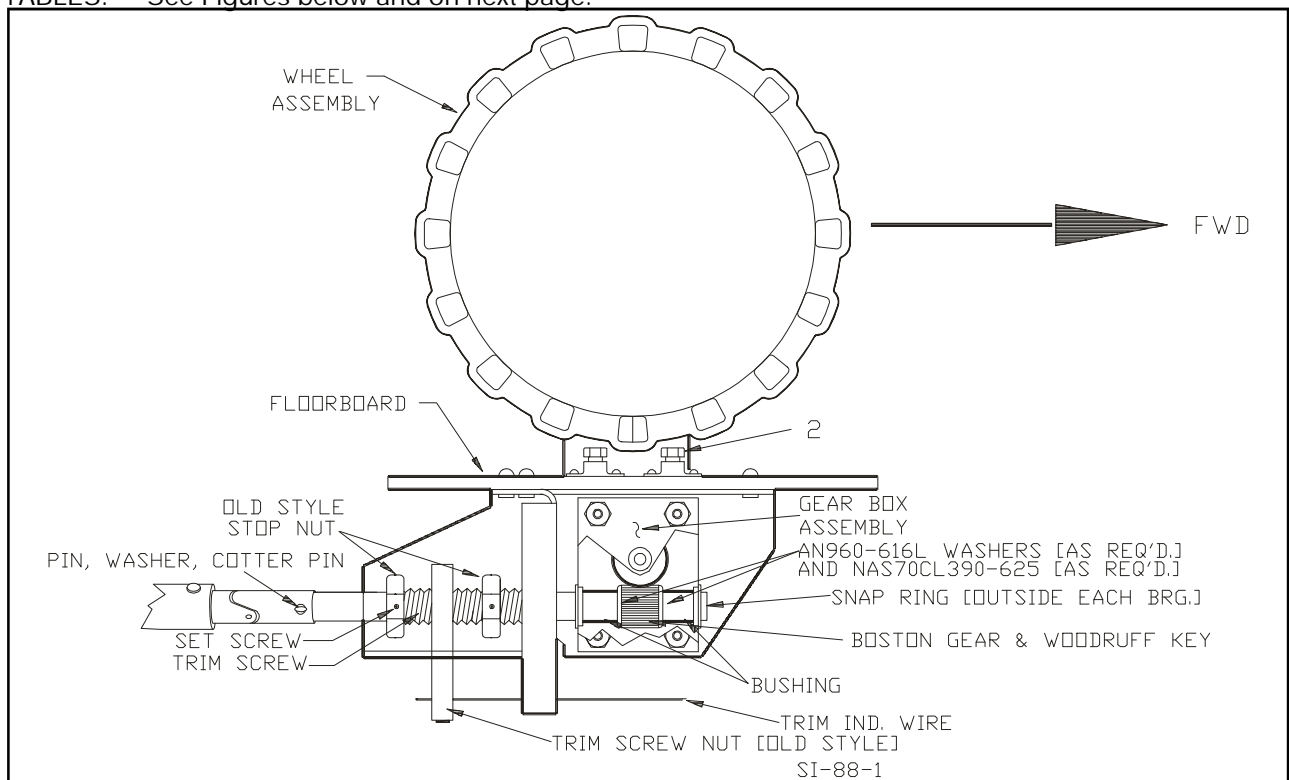

FIGURE SI M20-88-1

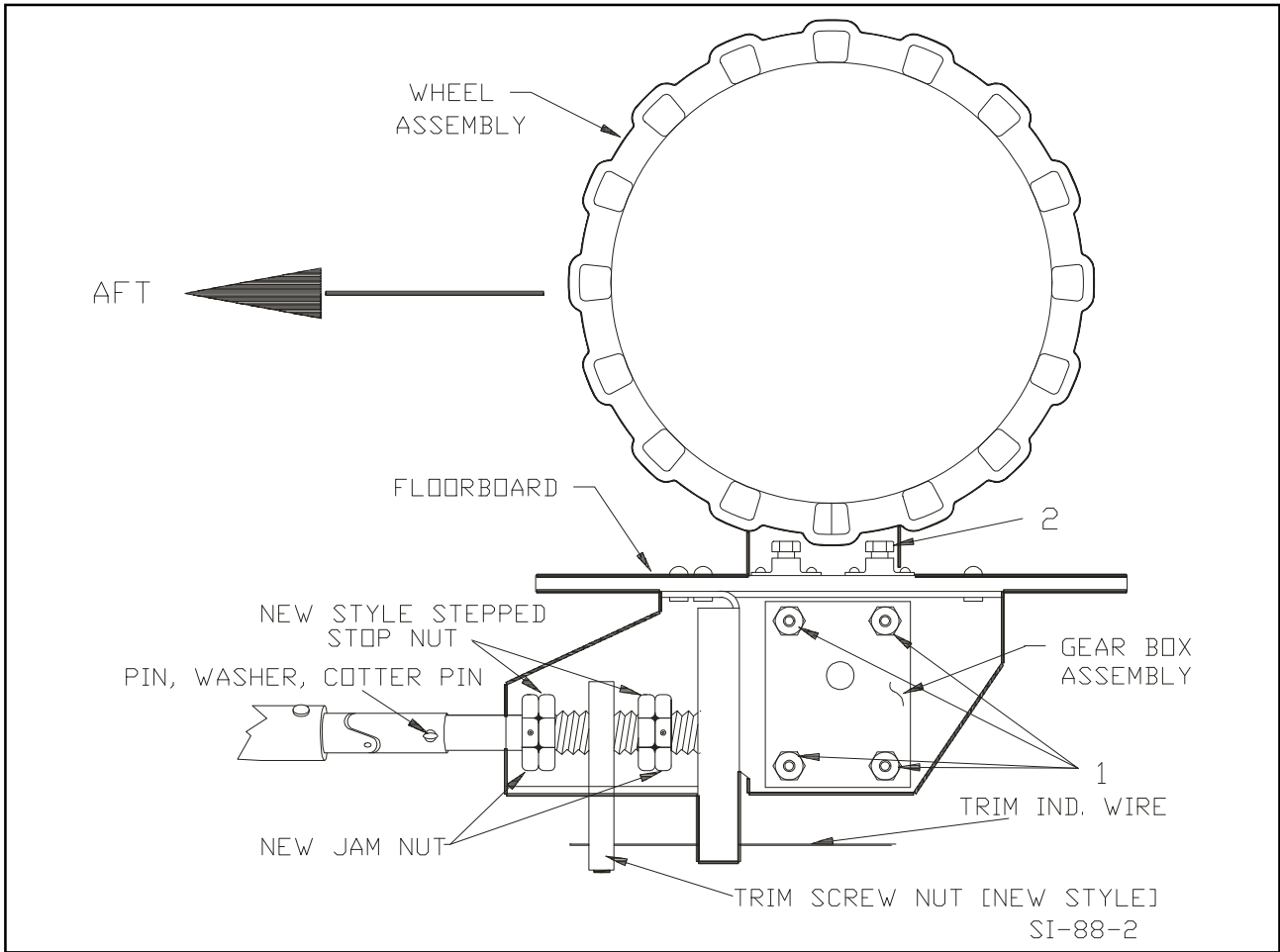

FIGURE SI M20-88-2